

Teatr Wielki POLISH NATIONAL OPERA

www.teatr Wielki.pl

Installed Products

RSS M-400 Digital Mixing Console
 RSS S-4000S-3208 Digital Snake
 RSS S-1608 Digital Snake
 RSS SC-W100S REAC Cabel
 REAC Recording System
 (REAC Driver, EDIROL FA-66)
 EDIROL LVS-400 Video Switcher

System Integration

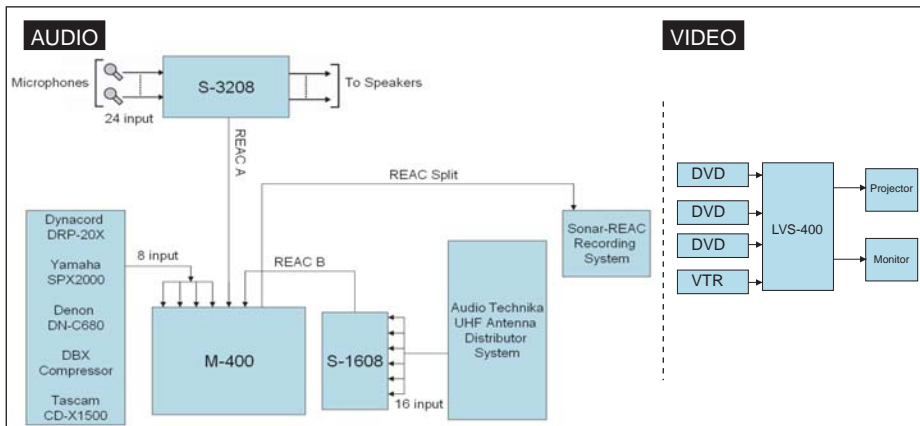

Introduction

The Stanislaw Moniuszko Grand Theatre (Polish Composer of patriotic and folk operas), was built in less than two years and has been opened since 1910. Since 1919 it is the house for the Polish Opera Theatre. Today world class soloists give recitals here and the opera cooperates with excellent theatres in Europe co-producing performances known beyond Polish borders. In the permanent repertoire are 40 operas and 15 ballets with new projects continually being added to develop the Theatre as an international value for Polish and world opera.

The System

Audio

The S-4000-3208(32 inputs) digital snakes are used on stage with 24 microphones of inputs. Eight local inputs are used for CD players and effector/processors. This System is also includes the SONAR REAC Recording System. The REAC Recording System can record up to 40CH over single Cat5e cable.

Video

The LVS-400 Video Switcher are used with DVD players and VTR(VHS). Output is provided to projector and monitor.

Point of Selection

Mr. Krystian Kołakowski

"We were looking for a solution to connect multiple consoles of FOH with a single connection system. Thanks to V-Mixing System we got a quite affordable and high quality audio mixing system. REAC provided us another benefit, multi-track recording of high quality sound with Cakewalk SONAR."

