

## Teatro Principal

www.teatroprincipalzaragoza.com

### Installed Products

- S-4000S-32x8 - 32 in x 8 out Modular Rack
- S-4000H 8x32 FOH unit
- S-4000R System Remote Control
- S-1608-16 in x 8 out Fixed Rack
- S-4000SP Splitter

### System Integration

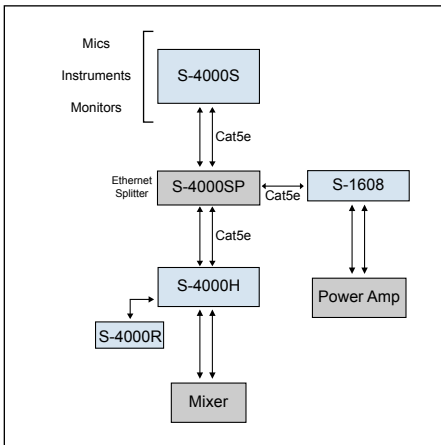

### Introduction

Founded on 25th of August 1799, the theatre was created to satisfy essential cultural needs of dance, opera, music and theatre. This neo-classical building, inspired by classical Italian theatres, has received several reformations and the last one being in 1987.

### The System

The main purpose of installing the CAT5e cabling, (instead of the traditional multicore cables) was to reinforce the idea of not damaging the traditional structure of this important building. Given the special characteristics (Plug & play) of the Digital Snake we were able to instal 6 different RJ-45 connections around the stage, from which we could link to the S-4000S Stage Unit. All RJ-45 connections terminated in the splitter and from there the signal goes to the main control area FOH (S-4000H) and another optional unit within the stalls area for possible connection to large consoles. In addition the FOH signal is sent to the main control room. Where we have a S-1608 with a direct connection to power amplifiers.

### Point of Selection

- Mr. Daniel Antolin - Tech. manager

Our basics needs were: to update the whole communication system without damage to or modification of the theatre's original structure and avoid using the old audio communication tubing, for this reason the selection of the cable CAT5e was a succes owing to its easy camouflaging within the structure of the theatre. Obviously, besides these needs, the most important point was, of course, high quality sound with total control from a distance of the pre-amplification zipper free (without steps in gain), without noise or R.F. in the signal. Another important point was to solve a typical theatre problem that is, the flexible location of the stage unit or FOH, for example, throughout the theatre with various RJ-45 points we can connect to a S-4000S Stage Unit with one or various FOH S-4000H units according to each show's need.



Overview of theatre



S-4000H in FOH



S-1608 in the machine room, along with Power amplifiers



S-4000SP Splitter