



<http://www.rampa.net>

Products

- M-400 V-Mixer Live Mixing Console
- S-1608 16 in x 8 Out Fixed Rack x 2
- S-0816 8 in x 16 out Fixed Rack x 2
- S-4000SP REAC Splitter

System Integration*

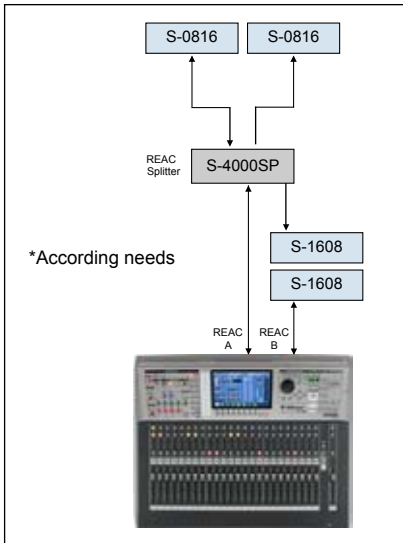

Introduction

Founded in 1989, Rampa has achieved a privileged position within the world of professional sound and illuminations in Spain. It counts on an important technical and human team that allows it to carry out great events, tours or projects, such as the prime time television program "La vida sigue igual" for Aragón TV, where they use different RSS equipment for the live program mix.

The System

The V-Mixing system is in charge of a permanent five-member orchestra in the program or musicians that are invited on the set, using two S-1608 stage sockets connected directly to the M-400 V-Mixer. The orchestra is in charge of handling live musical themes during interviews or commercial breaks. Once the mix has been made, it is sent to a central control, situated at a long distance from the set, through S-0816, whereby this signal is sent to two controls, depending on the necessities. Each program poses different setups and the V-Mixing system will have to adapt to the shipment, return or channel demands.

Point of Selection

- Alvaro Bitrian Technical Manager

The situation posed by the producer of this prime time television program was as follows: each program has a series of guests with a common subject, remembering the past in the first person, livened up by five live musicians, who reproduce the songs of that period in which the guest remembers his different experiences.

Furthermore, it might happen that the guest is a musician and that he also plays live. All of this has to be mixed and sent to the central control for its broadcasting. Since daily everything has to be disassembled after the program and the following week everything has to again be assembled, we needed a system with many integrated, effect type features, compressors and more, with high quality sound, being able to send to different long distance points and all of this is an accessible format, in order to situate the equipment on the set, without noises or parasites in the signal. We have many systems available in our installations, but the V-Mixer, due to its incredible features and quality, has been consolidated as a mix system.



2 S-1608, S-0816 and S-4000SP situated in channel TV set



The V-Mixer, M-400 in a set's corridor

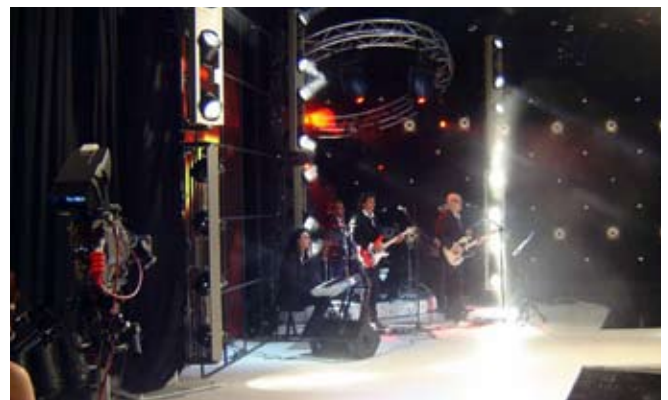

The Bogusband orchestra on the set of "La vida sigue igual"