

# Sound Design precisely based on the concept

## Hanshin Railways Umeda 2nd Building (Harbis ENT)

<http://www.herbis-ent.com/>

### Introduction

Harbis ENT located at Umeda, Osaka city is a commercial complex opened in Nov., 2004. It contains large shopping malls, theaters, live houses and offices inside. The basis concept is "Urban Entertainment Complex". Guests may find themselves like straying in movie scenes while they are in this building.

### Point of selection

We selected AR series for its easy maintenance and AR Link function for multi channel output.

We requested composers to make original songs for Linear Cascade and 4 artists came to here to track down the songs. It made the song extremely suitable to the building and basic concept. They used Protools for mixing and track down. It was possible to dump the digital data directly to AR-3000/200 and made the work very smooth and speedy.

### System

At the central area of this building, we have Linear Cascade Zone. We entertain our guests with lighting and sound. We use AR-3000 and AR-200 x 12 as sound source of this area.

### Installed Equipment

Audio Recorder	AR-3000
Audio Recorder	AR-200
Synthesizer	Fantom-XR
Digital EQ	RDQ-2031
MIDI Patch Bay	UM-880



▲Harbis ENT

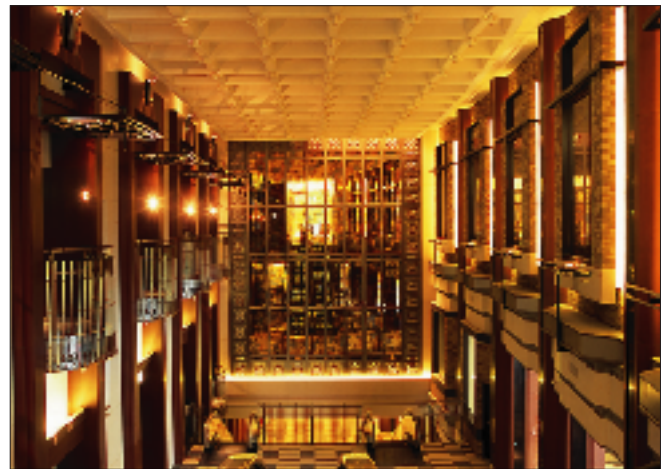

▲Linear Cascade Zone

### System Integration

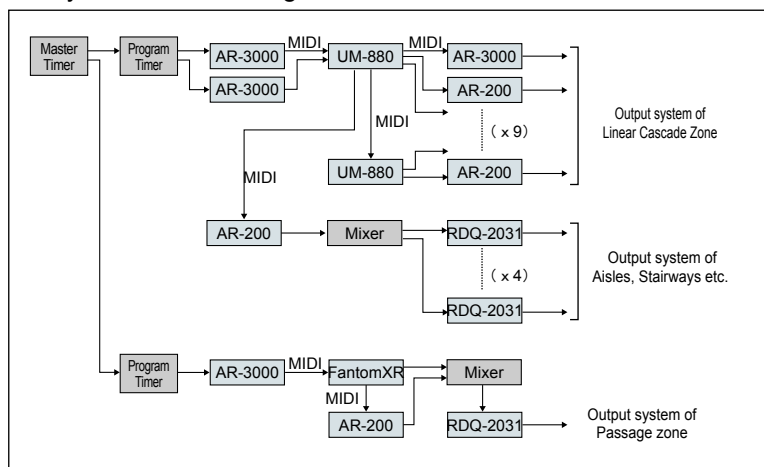

▲Equipment in Rack