

Daiichi Kosho Co., Ltd.
www.dkkaraoke.co.jp

Introduction

Since its establishment in 1973, Daiichi Kosho provides a place for communication and expansion of music culture through Karaoke. A well-known Karaoke place called "Big Echo" is the largest Karaoke chain with 229 locations all over Japan. Daiichi Kosho uses in-house produced background video content for Karaoke. The need for HD content is continuing to grow every year.

The Point of Selection

- Mr. Hatayama, Production Dept of Daiichi Kocho

Our staffs were looking at replacing our current SD equipment for HD production equipment but needed to consider cost performance and speed of production. Our reserch found that the best solution was to find a device that did HD-SDI output and recorded to HDV as a backup. Upon conclusion of their research we found that the VC-300HD was the only device that met our specific needs. Only 1RU high installed, transporting 3 VC-300HD's was very practical and efficient. Often we need to take these units outdoors to connect analog component video from any HD camera. Portability and analog input is one of the most important functions of the VC-300HD. Our second consideration in a converter was the audio capability. Embedded audio function with delay was a necessary function for Karaoke application.

Installed Products

VC-300HD Multi Format Converter

System Integration

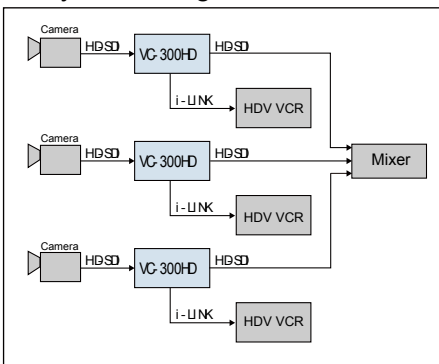

The System

Daiichi Kosho Co., purchased 3 VC-300HD to use with 3 HD-SDI cameras. The signal from each camera is split to SDI and HDV. The SDI streams go into the video mixer for master output. HDV streams are recorded to VCR as backup. VC-300HD has the ability to simultaneously record high quality HDV and output HD-SDI at the same time in a single unit.



The Linear Editing Suite to create Karaoke video contents

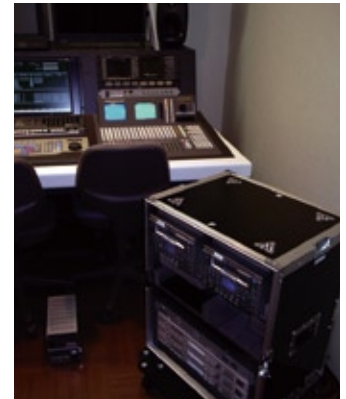

VC-300HD with various equipment



VC-300HD x 3 units installed in rack



Capable for outdoor use